

CERTIFICATE OF APPROPRIATENESS

Application Date: October 18, 2021

Applicant: Jeremy Dean, owner / Sam Gianukos, agent

Property: 3013 Beauchamp St, Houston, TX, 77009; Lot 3 and 4, Block 8, Woodland Heights Subdivision.
The property includes a historic 2,465 square foot, one-story wood frame single family residence, situated on a 10,000 square foot (100' x 100') corner lot (information obtained from HCAD).

Significance: Contributing Craftsman Bungalow, constructed circa 1910, located in the Woodland Heights Historic District.

Proposal: Alteration & Addition:

- Construct a 2,345 square foot addition to the existing home and attached garage, bringing the total square footage to 4,733 square feet of conditioned space
- Match the existing finished floor height at 2'-0" (at the home) and 6" slab on grade at garage
- The existing roof pitch is 5/12 and 7/12, the addition shall be 6/12 (first floor) and 5/12 (second floor)
- Have an eave height of 22'-9" and a maximum ridge height of 30'-4"
- Install cementitious siding with a reveal to match the original siding
- Install inset and recessed wood windows

Public Comment: No public comment received.

Civic Association: No comment received.

Recommendation: Denial - does not satisfy criteria

HAHC Action: -

APPROVAL CRITERIA

ALTERATIONS, REHABILITATIONS, RESTORATIONS AND ADDITIONS

Sec. 33-241: HAHC shall issue a certificate of appropriateness for the alteration, rehabilitation, restoration or addition of an exterior feature of (i) any landmark, (ii) protected landmark, (iii) any building, structure or object that is part of an archaeological site, or (iv) contributing building in a historic district upon finding that the application satisfies the following criteria, as applicable:

S D NA S - satisfies D - does not satisfy NA - not applicable

- (1) The proposed activity must retain and preserve the historical character of the property;
(2) The proposed activity must contribute to the continued availability of the property for a contemporary use;
(3) The proposed activity must recognize the building, structure, object or site as a product of its own time and avoid alterations that seek to create an earlier or later appearance;
(4) The proposed activity must preserve the distinguishing qualities or character of the building, structure, object or site and its environment;
(5) The proposed activity must maintain or replicate distinctive stylistic exterior features or examples of skilled craftsmanship that characterize the building, structure, object or site;
(6) New materials to be used for any exterior feature excluding what is visible from public alleys must be visually compatible with, but not necessarily the same as, the materials being replaced in form, design, texture, dimension and scale;
(7) The proposed replacement of exterior features, if any, should be based on an accurate duplication of features, substantiated by available historical, physical or pictorial evidence, where that evidence is available, rather than on conjectural designs or the availability of different architectural elements from other structures;
(8) Proposed additions or alterations must be done in a manner that, if removed in the future, would leave unimpaired the essential form and integrity of the building, structure, object or site;
(9) The proposed design for any exterior alterations or addition must not destroy significant historical, architectural, archaeological or cultural material, including but not limited to siding, windows, doors and porch elements;
(10) The proposed alteration or addition must be compatible with the massing, size, scale material and character of the property and the context area; and
(11) The distance from the property line to the front and side walls, porches, and exterior features of any proposed addition or alteration must be compatible with the distance to the property line of similar elements of existing contributing structures in the context area.



PROPERTY LOCATION
WOODLAND HEIGHTS HISTORIC DISTRICT

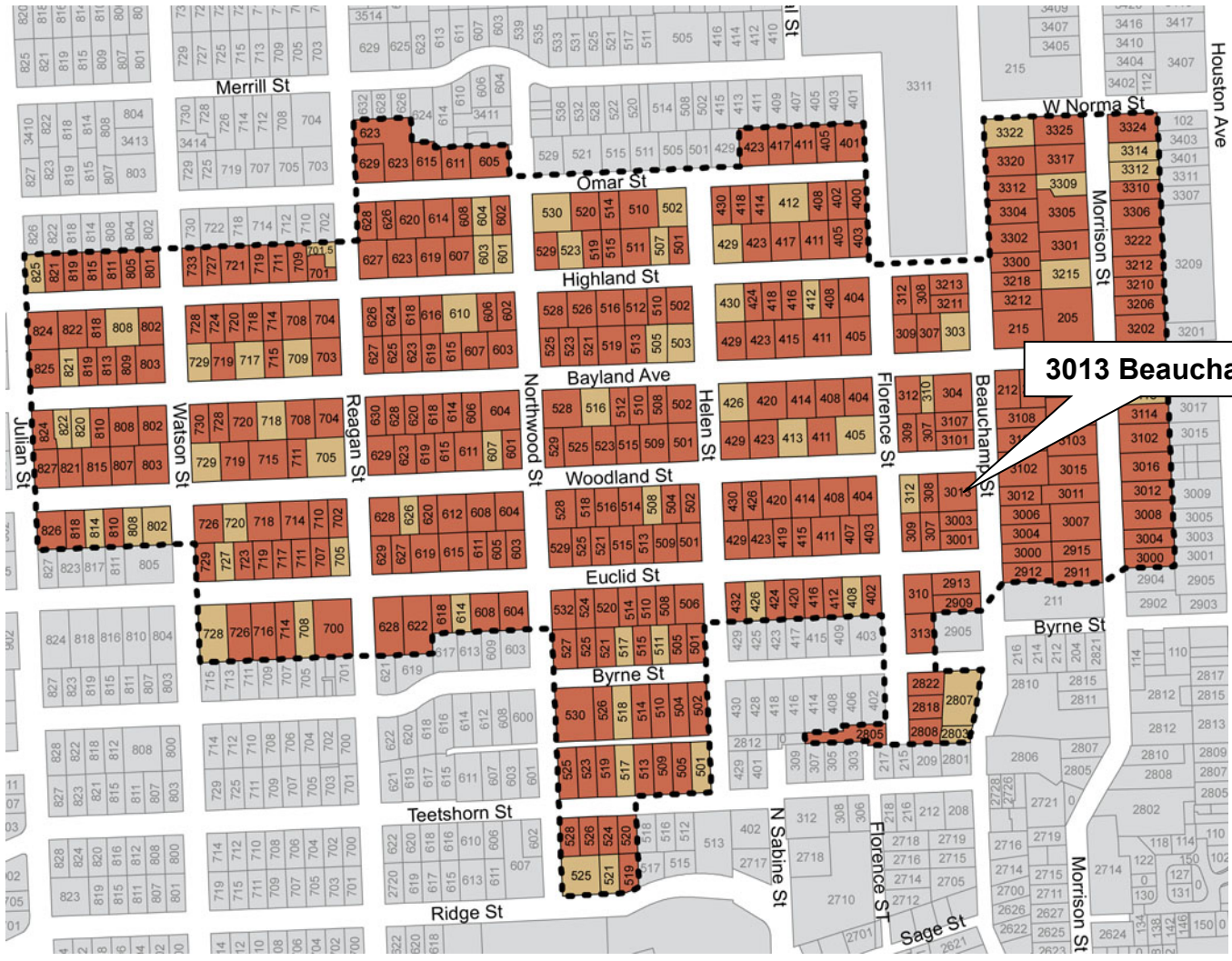

3013 Beauchamp

- Building Classification**
- Contributing
 - Non-Contributing
 - Park

INVENTORY PHOTO



CURRENT PHOTO



CONTEXT AREA



3003 Beauchamp

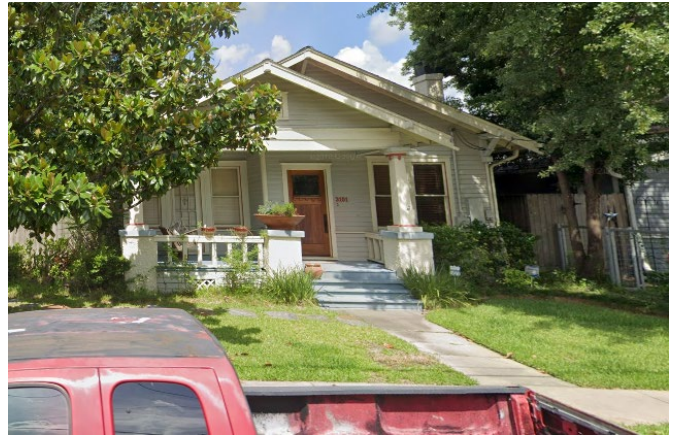

3106 Beauchamp



3006 Beauchamp



3006 Beauchamp



3012 Beauchamp



3012 Beauchamp



SITE PLAN EXISTING

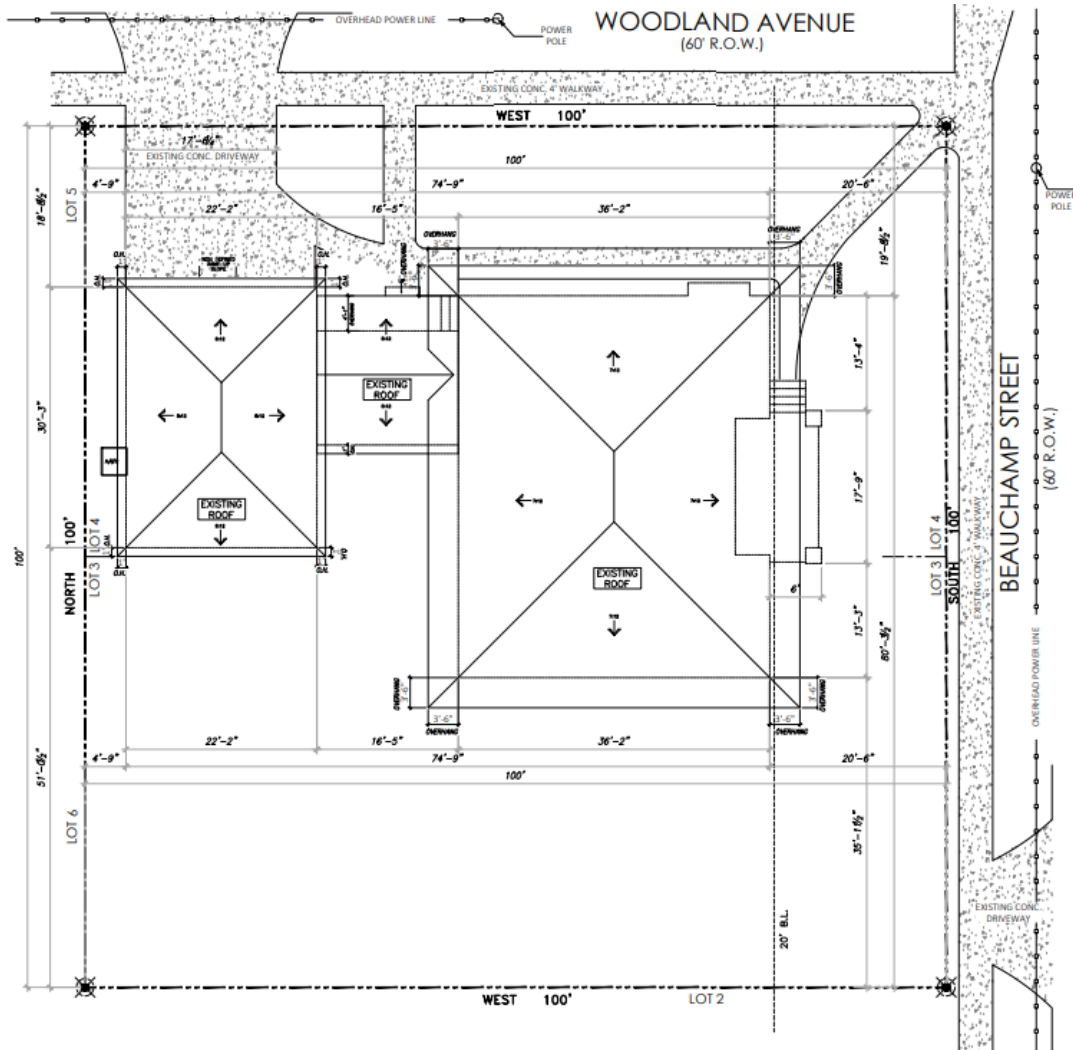



PROPOSED

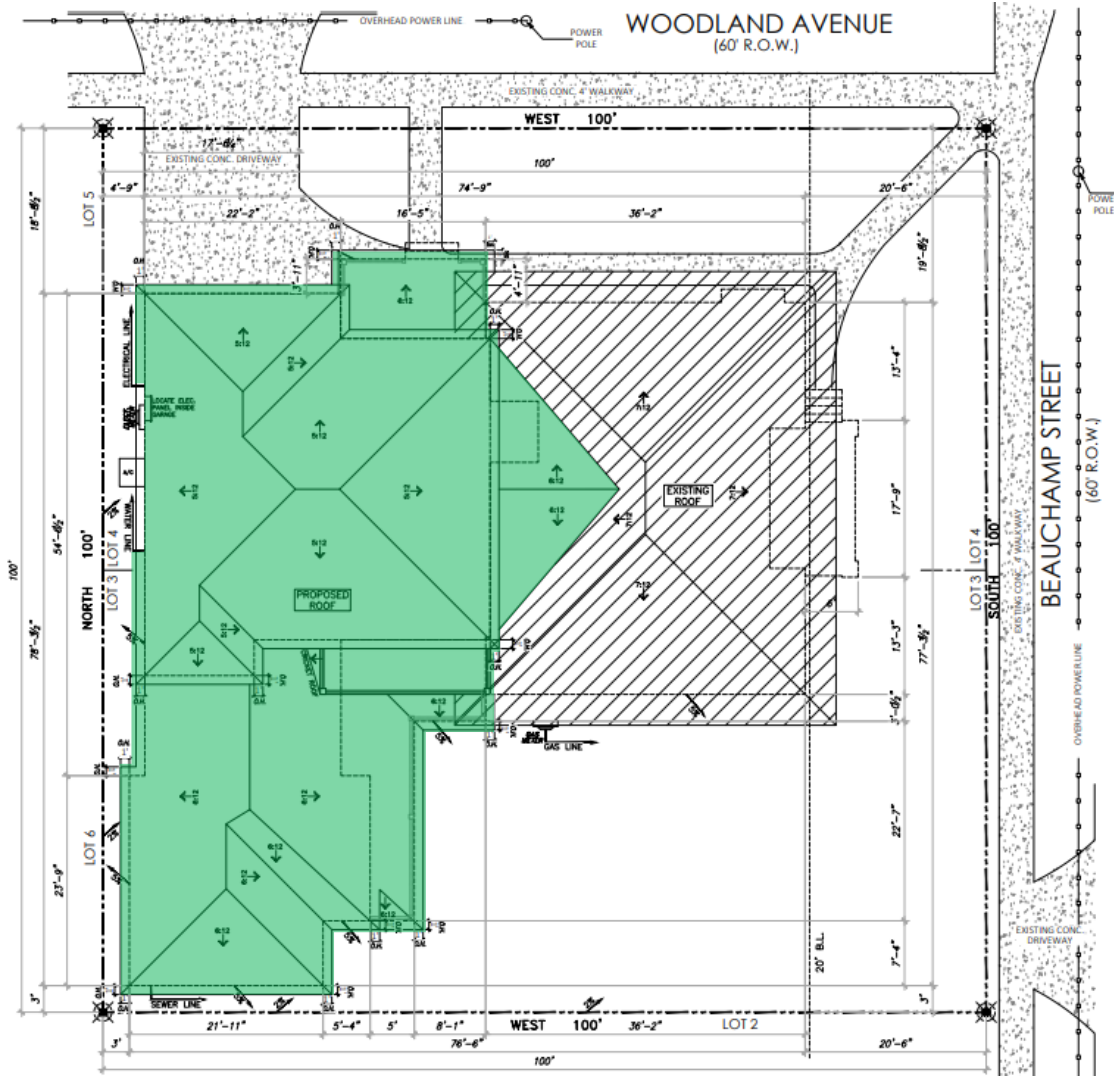



ROOF PLAN

EXISTING

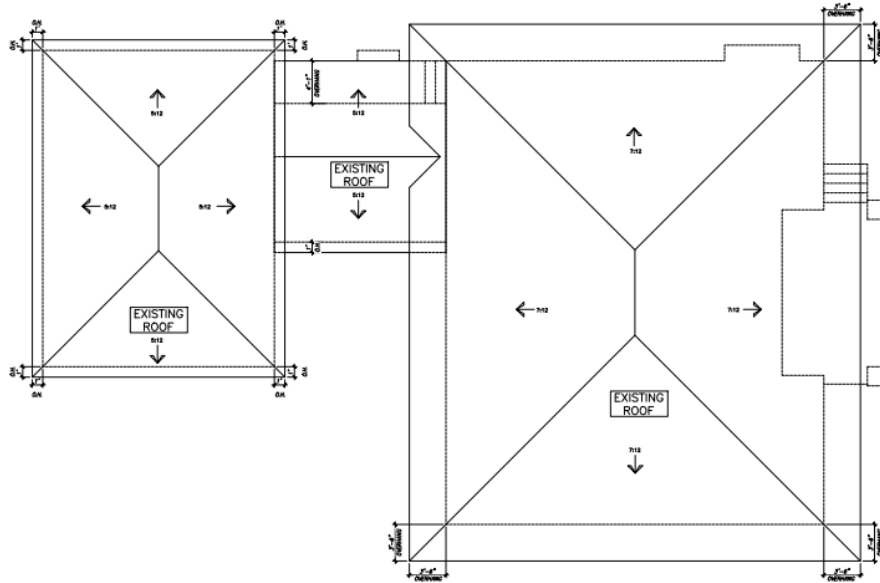

PROPOSED

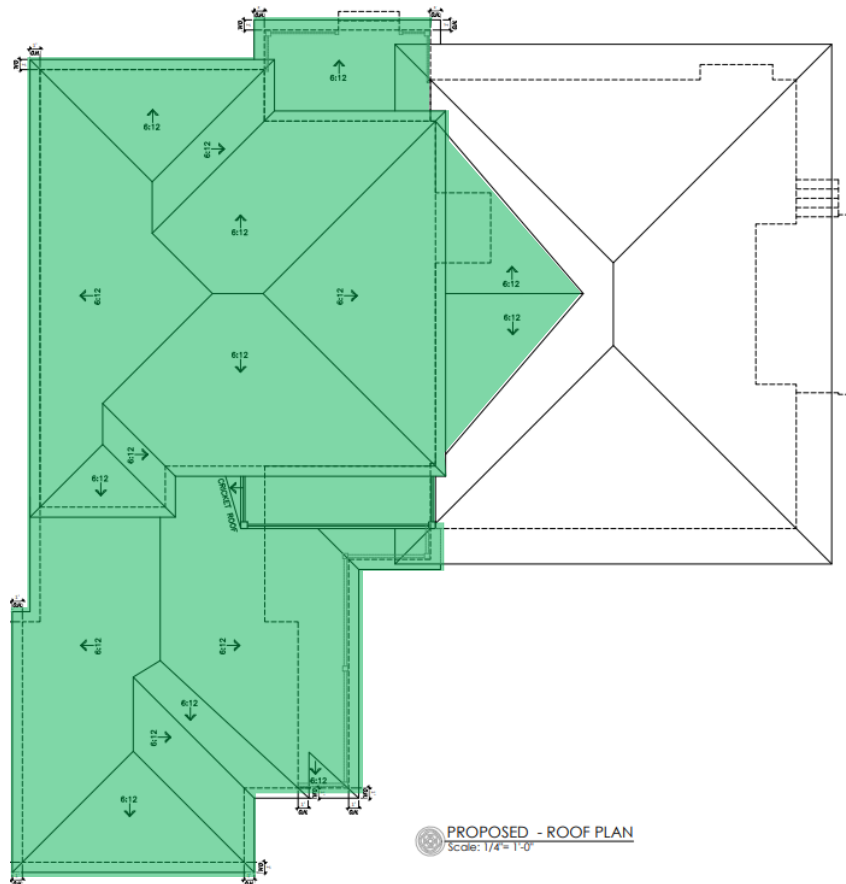

PROPOSED - ROOF PLAN
Scale: 1/4" = 1'-0"



FIRST FLOOR PLAN EXISTING

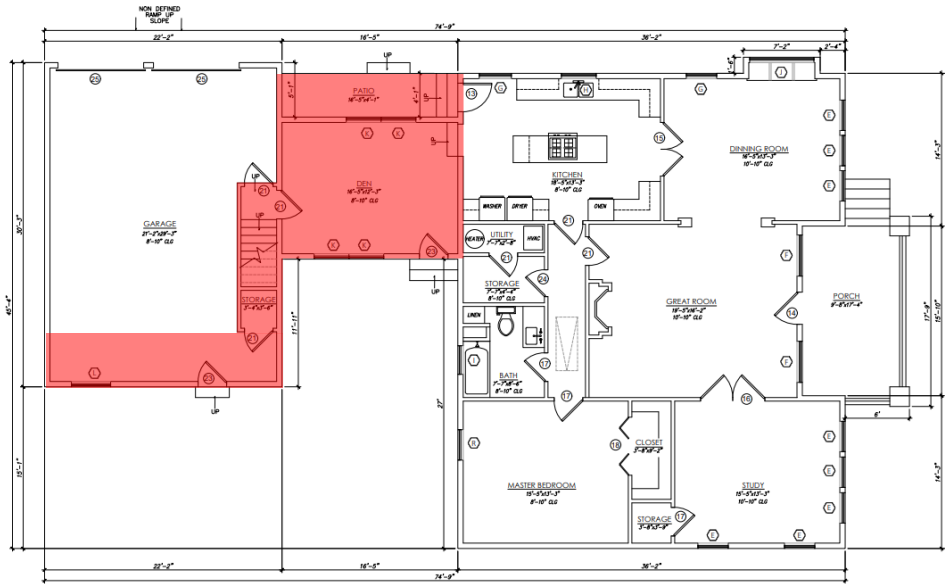

FIRST FLOOR PLAN PROPOSED

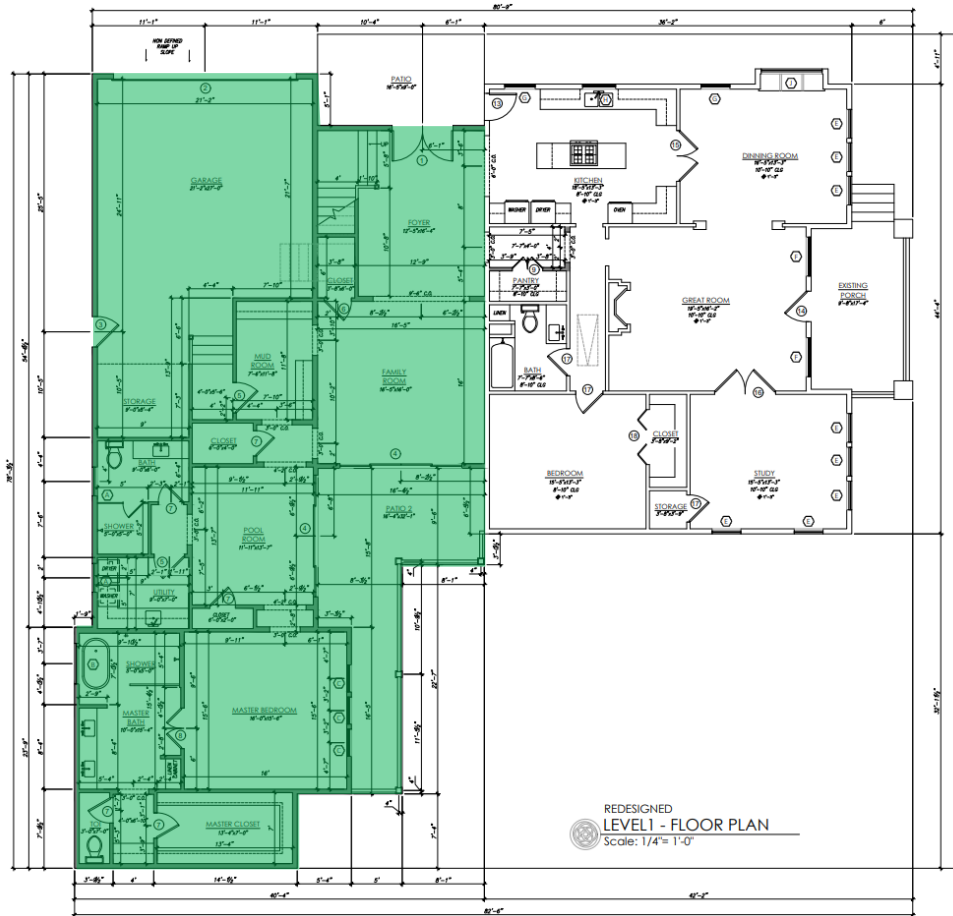



SECOND FLOOR PLAN
EXISTING (GARAGE)

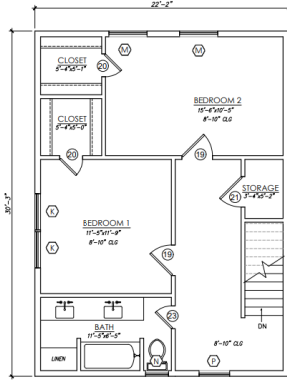

PROPOSED

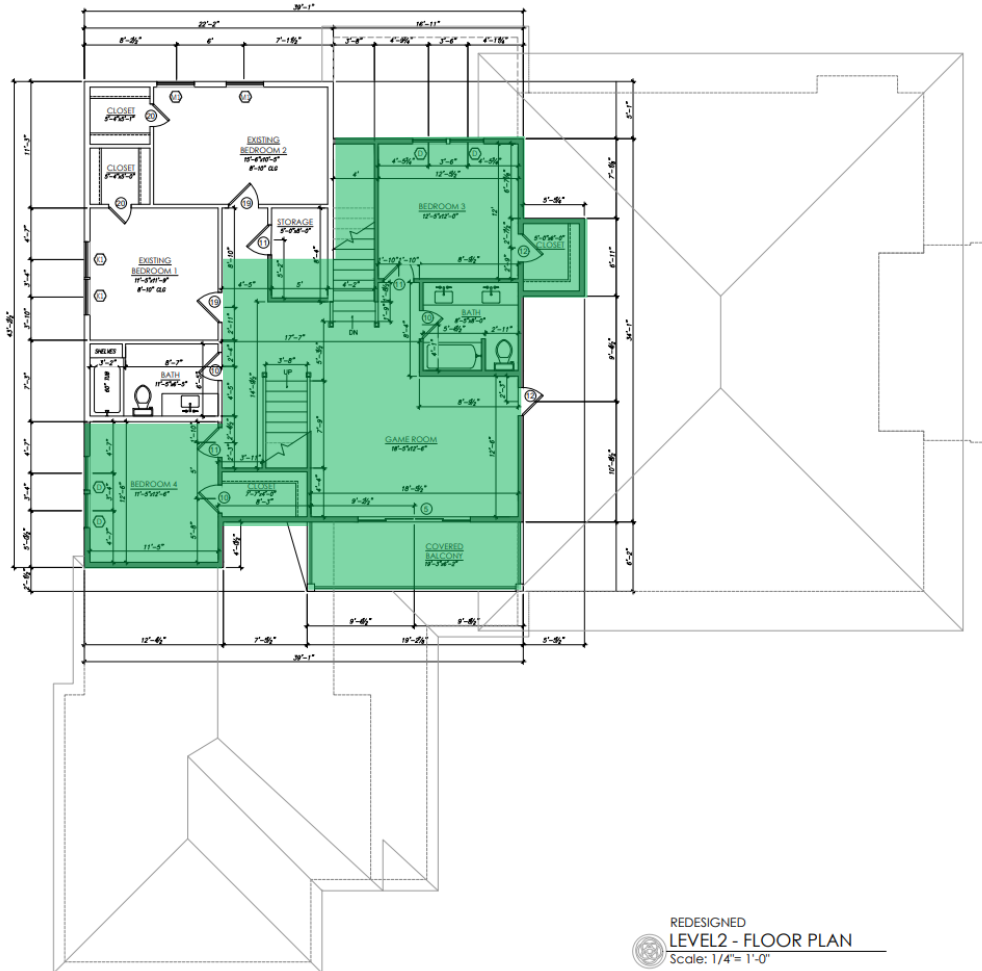

REDESIGNED
LEVEL 2 - FLOOR PLAN
 Scale: 1/4" = 1'-0"

EAST ELEVATION – FRONT FACING BEAUCHAMP STREET

EXISTING



PROPOSED

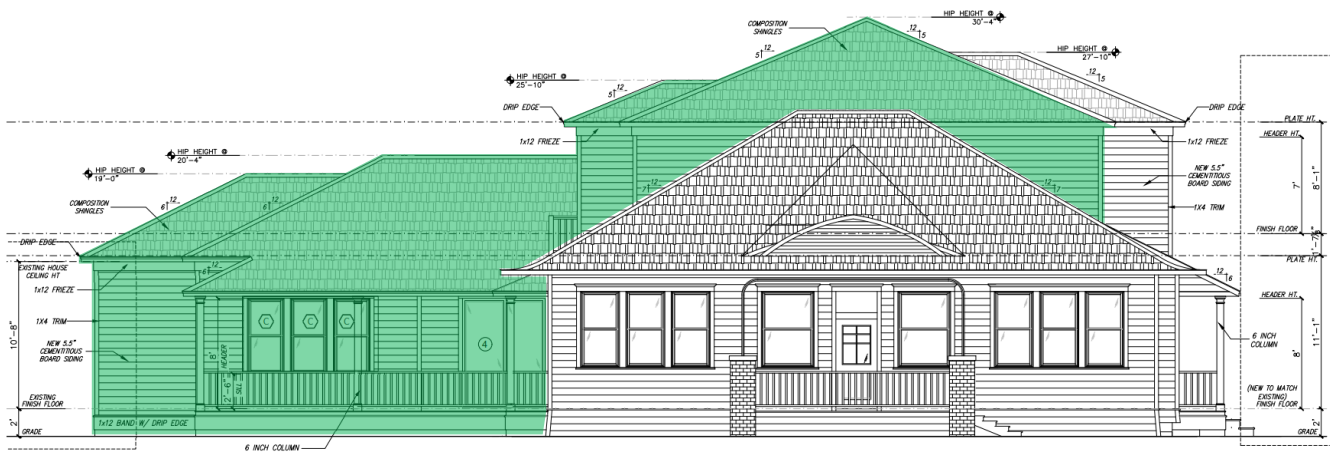

**NORTH SIDE ELEVATION
 EXISTING**



PROPOSED

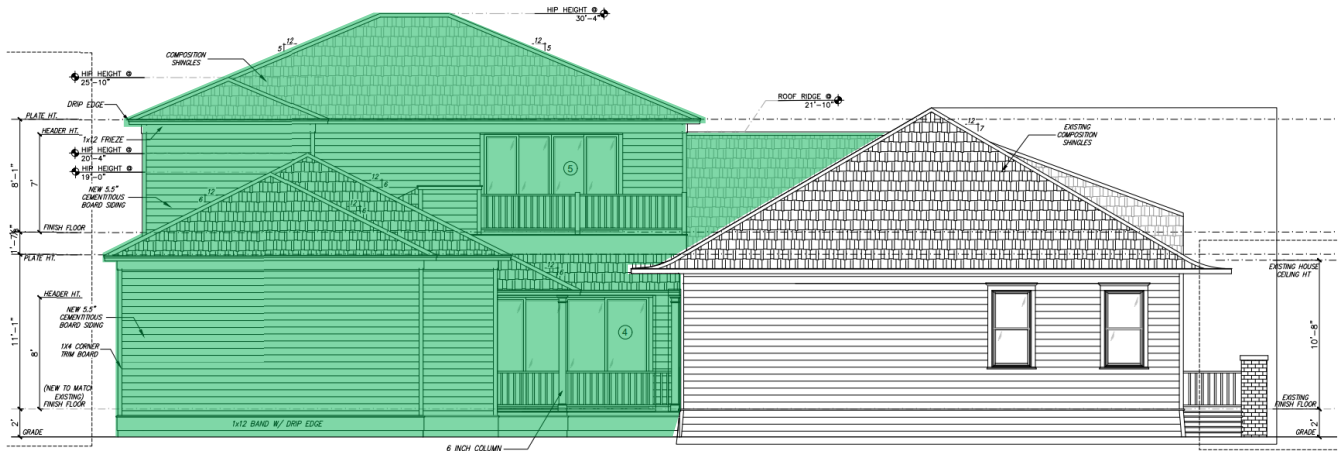

SOUTH SIDE ELEVATION

EXISTING

Scale: 1/4" = 1'-0"

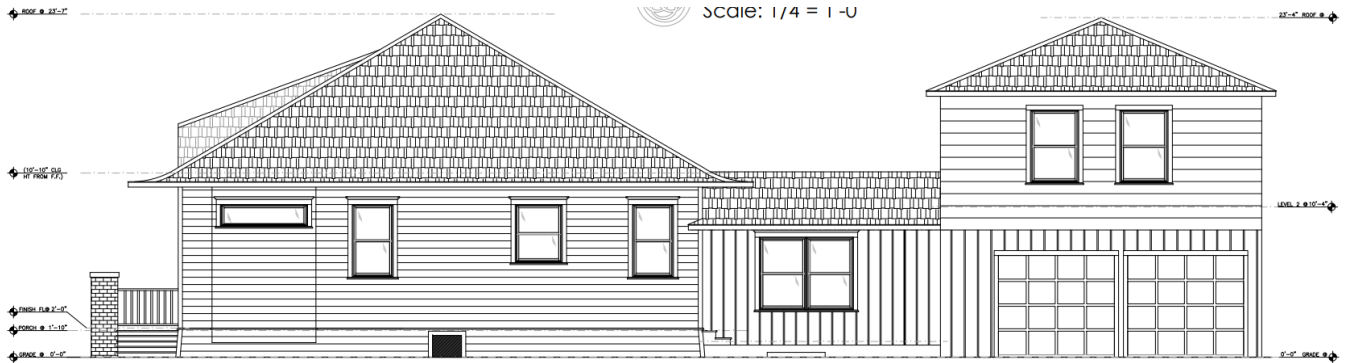

PROPOSED

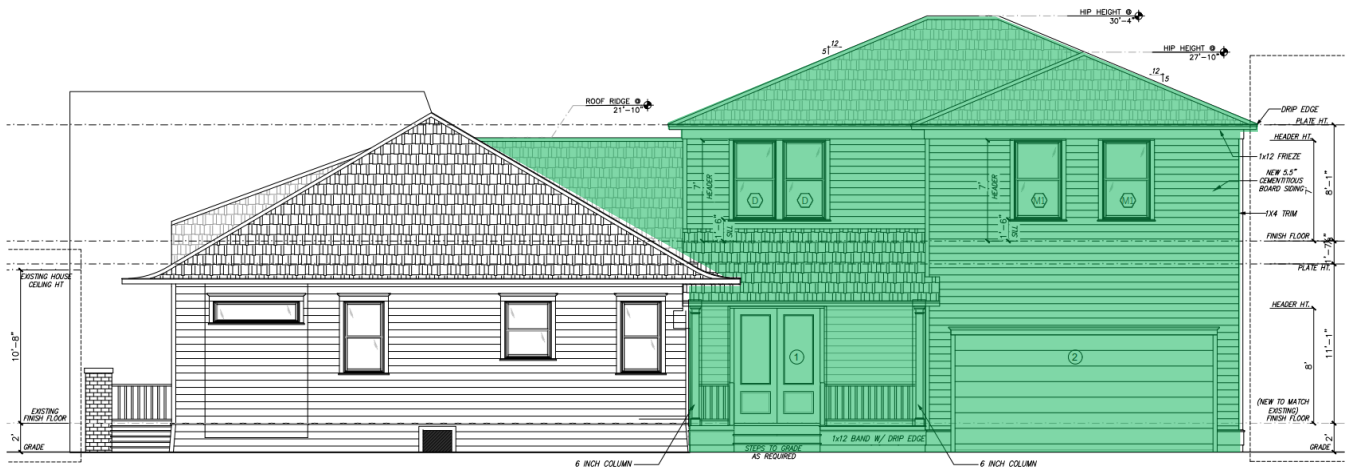

WEST (REAR) ELEVATION
EXISTING



PROPOSED

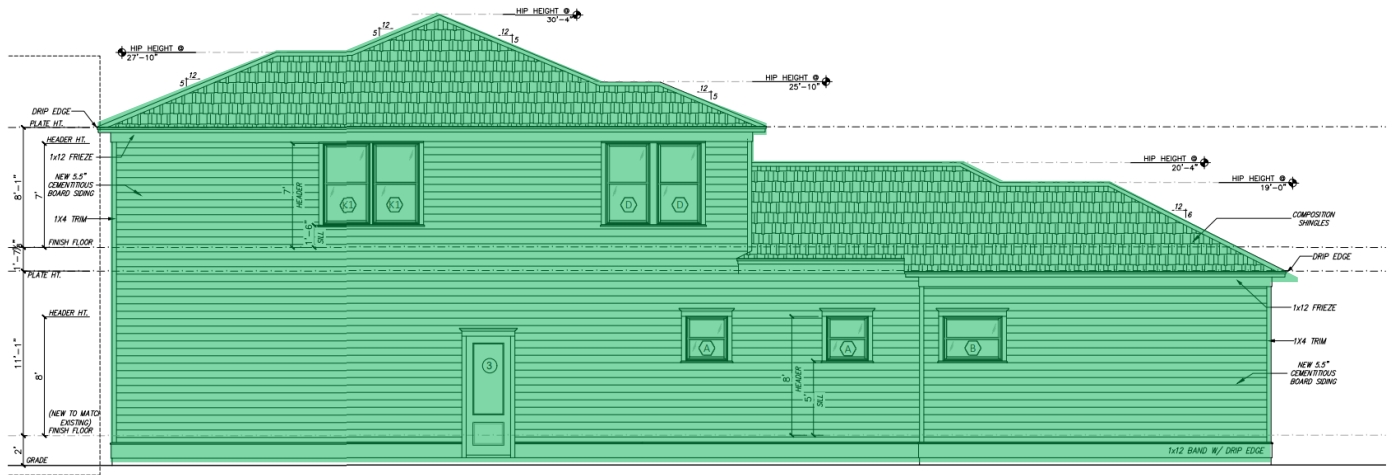

WINDOW / DOOR SCHEDULE

WINDOW SCHEDULE				
MARK	QTY	WIDTH	HEIGHT	DESCRIPTION
(A)	2	2'-10"	3'-0"	SINGLE HUNG
(B)	1	4'-0"	3'-0"	SINGLE HUNG
(C)	3	2'-8"	5'-6"	SINGLE HUNG
(D)	4	3'-0"	5'-6"	SINGLE HUNG
(M)	2	3'-4"	5'-0"	SINGLE HUNG
(K)	2	3'-2"	5'-0"	SINGLE HUNG

WINDOW SCHEDULE					
MARK	QTY	WIDTH	HEIGHT	DESCRIPTION	
(E)	7	2'-10"	5'-6"	SINGLE HUNG	REMAIN TO EXIST
(F)	2	3'-10"	5'-6"	SINGLE HUNG	REMAIN TO EXIST
(G)	2	2'-10"	5'-0"	SINGLE HUNG	REMAIN TO EXIST
(H)	1	3'-2"	4'-0"	SINGLE HUNG	REMAIN TO EXIST
(J)	1	1'-6"	6'-0"	FIXED TRANSOM	REMAIN TO EXIST
(I)	1	2'-10"	3'-0"	SINGLE HUNG	TO DEMOLISH
(K)	6	3'-2"	5'-0"	SINGLE HUNG	TO DEMOLISH
(L)	1	3'-8"	4'-0"	SINGLE HUNG	TO DEMOLISH
(M)	2	3'-4"	5'-0"	SINGLE HUNG	TO DEMOLISH
(N)	1	2'-0"	5'-0"	SINGLE HUNG	TO DEMOLISH
(P)	1	2'-8"	5'-0"	SINGLE HUNG	TO DEMOLISH
(R)	1	2'-10"	5'-6"	SINGLE HUNG	TO DEMOLISH

DOOR SCHEDULE				
DOOR NO.	QTY	WIDTH	HEIGHT	DESCRIPTION
1	1	(2) 3'-0"	8'-0"	(2)3080 EXTERIOR WITH GLASS PANEL, PAIR DOOR
2	1	18'-0"	8'-0"	GARAGE DOOR
3	1	3'-0"	8'-0"	EXTERIOR WITH GLASS PANEL DOOR
4	2	12'-0"	8'-0"	EXTERIOR 4 PANEL SLIDING GLASS DOOR
5	1	10'-0"	7'-0"	EXTERIOR 4 PANEL SLIDING GLASS DOOR
5	2	3'-0"	8'-0"	INTERIOR DOOR
6	1	2'-8"	8'-0"	INTERIOR DOOR
7	5	2'-6"	8'-0"	INTERIOR DOOR
8	1	(2) 2'-0"	8'-0"	(2)2080 INTERIOR, PAIR DOOR
9	1	(2) 1'-6"	8'-0"	(2)1680 INTERIOR, PAIR DOOR
10	3	2'-6"	7'-0"	INTERIOR DOOR
11	3	2'-8"	7'-0"	INTERIOR DOOR
12	2	2'-6"		INTERIOR DOOR, CUT TO FIT (ATTIC ACCESS)

DOOR SCHEDULE					
DOOR NO.	QTY	WIDTH	HEIGHT	DESCRIPTION	
13	1	2'-8"	7'-0"	EXTERIOR DOOR	REMAIN TO EXIST
14	1	3'-0" 3'-0"	7'-0" 1'-6"	EXTERIOR DOOR WITH TRANSOM WITH 6" MULE	REMAIN TO EXIST
15	1	(2) 2'-6"	7'-0"	(2)2670 INTERIOR, PAIR DOOR	REMAIN TO EXIST
16	1	(2) 3'-0"	8'-0"	(2)3070 INTERIOR, PAIR DOOR	REMAIN TO EXIST
17	3	2'-8"	8'-0"	INTERIOR DOOR	REMAIN TO EXIST
18	1	(2) 2'-8"	8'-0"	(2)2880 INTERIOR, BIFOLD PAIR	REMAIN TO EXIST
19	1	2'-8"	7'-0"	INTERIOR DOOR	REMAIN TO EXIST
20	1	2'-0"	7'-0"	INTERIOR DOOR	REMAIN TO EXIST
21	7	2'-8"	7'-0"	INTERIOR DOOR	TO DEMOLISH
22	1	2'-0"	7'-0"	INTERIOR DOOR	TO DEMOLISH
23	2	2'-8"	7'-0"	EXTERIOR DOOR	TO DEMOLISH
24	1	2'-6"	7'-0"	INTERIOR DOOR	TO DEMOLISH
25	2	8'-0"	7'-0"	EXTERIOR GARAGE DOOR	TO DEMOLISH

NEW LOT CALCULATION OF IMPERVIOUS PERCENTAGE	
HOUSE	4,538 SQ.FT.
DRIVEWAY	745 SQ.FT.
TOTAL IMPERVIOUS COVER	5,283 SQ.FT.
LOT AREA	10,000 SQ.FT.
PERCENTAGE IMPERVIOUS AREA	52.38 %

AREA CALCULATIONS			
	EXISTING	+/-	REDESIGNED
FIRST FLOOR:	1829 SQ.FT.	+1431	3260 SQ.FT.
SECOND FLOOR:	636 SQ.FT.	+837	1473 SQ.FT.
TOTAL HEATED :	2465 SQ.FT.	+2268	4733 SQ.FT.
PATIO:	67 SQ.FT.	+81	148 SQ.FT.
PORCH:	164 SQ.FT.	-	164 SQ.FT.
PATIO 2:	-	+300	300 SQ.FT.
GARAGE+STORAGE :	610 SQ.FT.	+54	664 SQ.FT.
BALCONY :		+119	119 SQ.FT.
TOTAL UNHEATED:	841 SQ.FT.	+554	1395 SQ.FT.
TOTAL COVER:	3306 SQ.FT.	+2822	6128 SQ.FT.